

# OPERATOR'S SAFETY AND SERVICE MANUAL



## AT73 AT84

This manual covers the following serial numbers  
and higher for each model listed:

ATS73 .....	4070001
ATP73 .....	4070001
ATS84 .....	4080001
ATP84 .....	4080001



## SKID-STEER ROLLER ATTACHMENTS

**MBW, Inc.**  
250 Hartford Rd • PO Box 440  
Slinger, WI 53086-0440  
Phone: (262) 644-5234  
Fax: (262) 644-5169  
Email: [mbw@mbw.com](mailto:mbw@mbw.com)  
Website: [www.mbw.com](http://www.mbw.com)

**MBW (UK) Ltd.**  
Units 2 & 3 Cochrane Street  
Bolton BL3 6BN, England  
Phone: 44 (0) 01204 387784  
Fax: 44 (0) 01204 387797

**MBW France S.A.R.L**  
Z.A. d'Outreville  
5 rue Jean Baptiste Néron,  
60540 BORNEL  
France  
Phone: +33 (0) 3 44 07 15 96  
Fax: +33 (0) 3 44 07 41 28

L17993 / 05.11.E  
©MBW, Inc. 2007  
Printed in the USA

# TABLE OF CONTENTS

---

<b>Safety Information</b> .....	<b>1</b>	<b>Service</b> .....	<b>7</b>
Introduction .....	1	Torque Chart .....	7
Safety Precautions .....	1	Service Tools .....	7
Safety Decals .....	1	Replacing Shockmounts .....	7
<b>Specifications</b> .....	<b>3</b>	Replacing Input Seal .....	7
<b>Operation</b> .....	<b>4</b>	Removing Drive Coupler .....	7
Introduction .....	4	Installing Drive Coupler .....	8
Before Starting & Operating .....	4	Removing Exciter Bearings and Shaft .....	8
Connecting to Loader .....	4	Installing Exciter Bearings and Shaft .....	8
Operating .....	4	Parts Replacement Cycles and Tolerances .....	9
<b>Maintenance</b> .....	<b>5</b>	<b>Replacement Parts</b> .....	<b>11</b>
Maintenance Schedule .....	5	Drum Assembly .....	12
Fluid Levels .....	5	Main Assembly .....	14
Changing Exciter Oil .....	5	Spider Assembly .....	16
Checking Exciter Oil .....	6	<b>Warranty</b> .....	<b>18</b>



# **WARNING**



## **CALIFORNIA PROPOSITION 65 WARNING**

Engine exhaust and some of its constituents are known in the state of California to cause cancer, birth defects, and other reproductive harm.

# SAFETY INFORMATION

## Introduction



This Safety Alert Symbol is used to call attention to items or operations which may be dangerous to those operating or working with this equipment. The symbol can be found throughout this manual and on the unit. Please read these warnings and cautions, along with all decals, carefully before attempting to operate the unit. Make sure every individual who operates or works with this equipment is familiar with all safety precautions.

### **WARNING**

**GENERAL WARNING.** Indicates information important to the proper operation of the equipment. Failure to observe may result in damage to the equipment and/or severe bodily injury or death.

### **CAUTION**

**GENERAL CAUTION.** Indicates information important to the proper operation of the equipment. Failure to observe may result in damage to the equipment.

## Safety Precautions



**LETHAL EXHAUST GAS:** An internal combustion engine discharges carbon monoxide, a poisonous, odorless, invisible gas. Death or serious illness may result if inhaled. Operate only in an area with proper ventilation. **NEVER OPERATE IN A CONFINED AREA!**



**DANGEROUS FUELS:** Use extreme caution when storing, handling and using fuels, as they are highly volatile and explosive in vapor state. Do not add fuel while engine is running. Stop and cool the engine before adding fuel. **DO NOT SMOKE!**



**SAFETY GUARDS:** It is the owner's responsibility to ensure that all guards and shields are in place and in working order.



**IGNITION SYSTEMS:** Breakerless, magneto, and battery ignition systems can cause severe electrical shocks. Avoid contacting these units or their wiring.



**SAFE DRESS:** Do not wear loose clothing, rings, wristwatches, etc. near machinery.



**NOISE PROTECTION:** Wear OSHA specified hearing protection devices.



**EYE PROTECTION:** Wear OSHA specified eye shields, safety glasses, and sweat bands.



**FOOT PROTECTION:** Wear OSHA specified steel-tipped safety shoes.



**HEAD PROTECTION:** Wear OSHA specified safety helmets.



**DUST PROTECTION:** Wear OSHA specified dust mask or respirator.

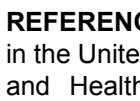

**OPERATOR:** Keep children and bystanders off and away from the equipment.

**REFERENCES:** For details on safety rules and regulations in the United States, contact your local Occupational Safety and Health Administration (OSHA) office. Equipment operated in other countries must be operated and serviced in accordance and compliance with any and all safety requirements of that country. The publication of these safety precautions is done for your information. MBW does not by the publication of these precautions, imply or in any way represent that these are the sum of all dangers present near MBW equipment. If you are operating MBW equipment, it is your responsibility to insure that such operation is in full accordance with all applicable safety requirements and codes. All requirements of the United States Federal Occupational Safety and Health Administration Act must be met when operated in areas that are under the jurisdiction of that United States Department.

## Safety Decals

Carefully read and follow all safety decals. Keep them in good condition. If decals become damaged, replace as required. If repainting the unit, replace all decals. Decals are available from authorized MBW distributors. Order the decal set listed on the following page(s).

# Hydraulic Requirements

**PRESSURE:** 1500-3000 psi  
(103-207 bar)  
**FLOW:** 10-50 gpm  
(38-190 l/m)

← Return

← Pressure

## CAUTION



### HEAVY ATTACHMENT

Overloading skid loader could cause loader to pitch or tip forward.

Check lifting capacity of skid loader before hooking onto attachment.

Do not lift attachment over 12" (30cm) above ground level.



READ OPERATORS MANUAL BEFORE USING ATTACHMENT

# ATS84

17906 - ATS73  
17907 - ATP73  
17908 - ATS84  
17909 - ATP84  
(NOT IN DECAL SET)

14435

14435

## M-B-W INC.

02355  
(NOT IN DECAL SET)

14434

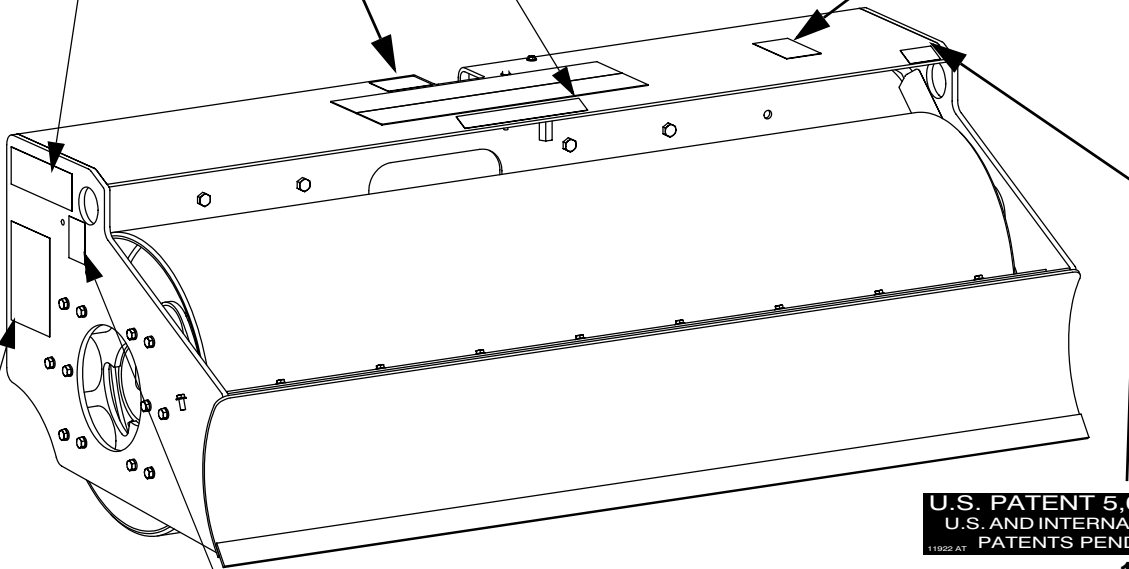

U.S. PATENT 5,062,228  
U.S. AND INTERNATIONAL PATENTS PENDING

11922



09867  
(NOT IN DECAL SET)

WARNING

Machine may fall and cause serious damage or injury if lifted improperly.  
Lift only by holes in frame above.

**MACHINE WEIGHT**

ATS84- 2300 lbs (1043 kg)  
ATP84- 2450lbs (1111 kg)

18075

18075-AT84  
18074-AT74 (Not Shown)

Safety Decals (Decal Set #14436)

# SPECIFICATIONS

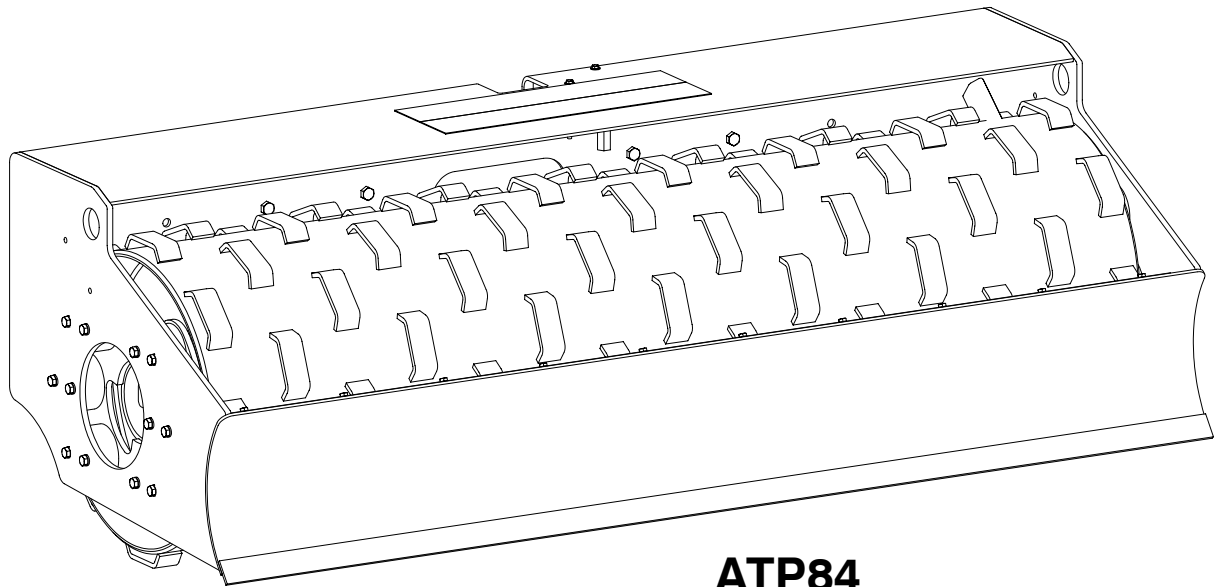

**ATP84**

	<b>ATS73</b>	<b>ATP73</b>	<b>ATS84</b>	<b>ATP84</b>
<b>Centrifugal Force</b>	8850 lbs (4014 kg)		9765 lbs (4429 kg)	
<b>Exciter Speed</b>	3000 rpm		3000 rpm	
<b>Dynamic Linear Force</b>	121 lb/in (21.7 kg/cm)		116 lb/in (20.8 kg/cm)	
<b>Amplitude</b>	-		-	
<b>Length</b>	43.3 in (110 cm)		43.3 in (110 cm)	
<b>Height</b>	29 in (74 cm)	30 in (76 cm)	29 in (74 cm)	30 in (76 cm)
<b>Weight</b>	2070 lbs (939kg)	2210 lbs (1002 kg)	2300 lbs (1043 kg)	2450 lbs (1111 kg)
<b>Width, Working</b>	73 in (185 cm)		84 in (213 cm)	
<b>Width, Overall</b>	78 in (198 cm)		89 in (226 cm)	
<b>Sound Pressure Level</b>	85 dBa		85 dBa	
<b>Pressure Requirement</b>	1500 - 3000 psi (10.3 - 20.7 MPa)		1500 - 3000 psi (10.3 - 20.7 MPa)	
<b>Flow Rate Requirement</b>	10 - 50 GPM (38 - 176 LPM)		10 - 50 GPM (38 - 176 LPM)	
<b>Connection</b>	1/2" Flat-face Quick Coupling		1/2" Flat-face Quick Coupling	

Specifications subject to change without notice

# OPERATION

---

## Introduction

MBW equipment is intended for use in very severe applications.

This parts manual contains only standard parts. Variations of these parts as well as other special parts are not included. Contact your local MBW distributor for assistance in identifying parts not included in this manual.

## Before Starting & Operating

- **REMEMBER!** It is the owner's responsibility to communicate information on the safe use and proper operation of this unit to the operators.
- Review ALL of the Safety Precautions listed on page 1 of this manual.
- Familiarize yourself with the operation of the machine and confirm that all controls function properly.
- Know how to STOP the machine in case of an emergency.
- Make sure hands, feet, and clothing are at a safe distance from any moving parts.

## Connecting to Loader

1. Attach the roller to the skid steer loader with the universal bracket. Be sure that the wedges and levers are fully engaged and locked.
2. Connect the hydraulic hoses to the skid steer loader's auxiliary hydraulics supply using the quick couplers.
3. If skid loader is equipped with a high flow and low flow ports, it is recommended to use the low flow side.

4. Lower the roller, and engage the loaders' arms into their float mode.
5. Engage the auxiliary hydraulics and allow the vibrator to come up to speed.

## Operating

- Check for loose hardware every 20 hours of operation.
- Do not run exciter when roller is not in contact with the ground.
- Check that rated capacity of skid steer loader meets or exceeds weight of roller attachment.
- The operating pressure supplied to the control valve must fall in the range of 1500 to 3000 psi.
- The minimum volume requirement supplied to the control valve is 10 gpm, but do not exceed 50 gpm.
- Do not use excessive down pressure when compacting soil.



**WARNING**



**Always stop the engine before:**

**Adding fuel.**

**Leaving the equipment unattended for any amount of time.**

**Before making any repairs or adjustments to the machine.**

---

# MAINTENANCE



## WARNING



Always exercise the stopping procedure before servicing or lubricating the unit.

After servicing the unit, replace and fasten all guards, shields, and covers to their original positions before resuming operation.



## CAUTION



Always verify fluid levels and check for leaks after changing fluids.

Do not drain oil onto ground, into open streams, or down sewage drains.

## Maintenance Schedule

SYSTEM	MAINTENANCE	EACH USE	EVERY 50 HOURS	EVERY 250 HOURS	YEARLY
Exciter	Check oil level		X		
	Check for oil leaks	X			
	Change oil			X	X
	Tighten Bolts <sup>1</sup>		X		X
Hardware	Check and tighten as needed <sup>1</sup>		X		X
Shock mounts	Check for cracks or tears		X		X

1. Check all hardware after the first 5 hours of use, then follow the maintenance schedule.

## Fluid Levels

SYSTEM	FLUID VOLUME	RECOMMENDED OIL
AT73 Exciter	80 oz.	MBW Ground Pounder <sup>®</sup> Exciter Oil <sup>1</sup>
AT84 Exciter	128 oz.	MBW Ground Pounder <sup>®</sup> Exciter Oil <sup>1</sup>

1. MBW #01058---- 6-Pack (8 oz. bottles)  
MBW #17320---- 1 quart (32 oz.)

## Changing Exciter Oil

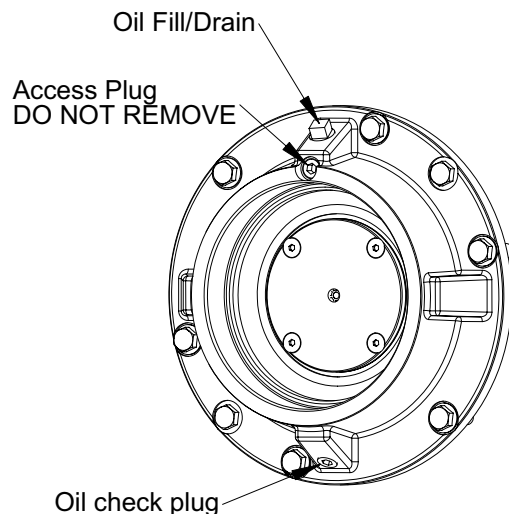

1. Rotate drum until the fill/drain plug is at bottom of drum. The fill/drain plug is the larger, square head plug on the vent side of the roller.
2. Place drain pan under plug and remove both plugs.
3. Raise driven side of drum several inches so all oil can drain out.
4. After all oil has drained, return drum to a level surface.
5. Rotate drum until fill/drain plug is at the top of the drum.
6. Remove oil check plug from bottom of cover. The oil check valve is smaller than the fill plug, and it has an allen head drive as opposed to the square head found on the fill/drain plug.



7. Fill exciter with MBW Ground Pounder® Exciter Oil until oil starts to drain from oil check plug. See chart for proper amounts.
8. Replace both plugs.

### **Checking Exciter Oil**

1. Place drum on a level surface

2. Remove oil check plug. The plug is the smaller of the two on the vent side which also has an allen head drive.
3. Rotate drum until check plug is at 6 o'clock position.
4. If oil level is adequate, it should dribble out of hole.
5. If necessary, remove fill/drain plug, and add MBW Ground Pounder® Exciter Oil.

# SERVICE

Assembly and disassembly should be performed by a service technician who has been factory trained on MBW equipment. The unit should be clean and free of debris. Pressure washing before disassembly is recommended.

- Prior to assembly, wash all parts in a suitable cleaner or solvent.
- Check moving parts for wear and failure. Refer to the Replacement section in this manual for tolerance and replacement cycles.
- All shafts and housings should be oiled prior to pressing bearings. Also, ensure that the bearings are pressed square and are seated properly.
- All bearings should be replaced when rebuilding any exciter or gearbox.
- All gaskets and seals should be replaced after any disassembly.

## Torque Chart

SIZE	GRADE 2	GRADE 5	GRADE 8
1/4-20	49 in·lbs	76 in·lbs	9 ft·lbs
1/4-28	56 in·lbs	87 in·lbs	10 ft·lbs
5/16-18	8 ft·lbs	13 ft·lbs	18 ft·lbs
5/16-24	9 ft·lbs	14 ft·lbs	20 ft·lbs
3/8-16	15 ft·lbs	23 ft·lbs	33 ft·lbs
3/8-24	17 ft·lbs	26 ft·lbs	37 ft·lbs
7/16-14	24 ft·lbs	37 ft·lbs	52 ft·lbs
7/16-20	27 ft·lbs	41 ft·lbs	58 ft·lbs
1/2-13	37 ft·lbs	57 ft·lbs	80 ft·lbs
1/2-20	41 ft·lbs	64 ft·lbs	90 ft·lbs
9/16-12	53 ft·lbs	82 ft·lbs	115 ft·lbs
5/8-11	73 ft·lbs	112 ft·lbs	159 ft·lbs
5/8-18	83 ft·lbs	112 ft·lbs	180 ft·lbs
3/4-16	144 ft·lbs	200 ft·lbs	315 ft·lbs
1-8	188 ft·lbs	483 ft·lbs	682 ft·lbs
1-14	210 ft·lbs	541 ft·lbs	764 ft·lbs
1-1/2-6	652 ft·lbs	1462 ft·lbs	2371 ft·lbs
M 6	3 ft·lbs	4 ft·lbs	7 ft·lbs
M 8	6 ft·lbs	10 ft·lbs	18 ft·lbs
M 10	10 ft·lbs	20 ft·lbs	30 ft·lbs

### CONVERSIONS

in·lbs x 0.083 = ft·lbs

ft·lbs x 12 = in·lbs

ft·lbs x 0.1383 = kg·m

ft·lbs x 1.3558 = N·m

## Service Tools

Part #	Description
07353	CLUTCH REMOVAL TOOL

## Replacing Shockmounts

1. Support roller to prevent it from rolling, and remove hydraulic hoses from motor.
2. Remove the two bolts securing the hydraulic motor and remove the motor.
3. Remove all external shockmount hardware while supporting frame. Lift frame assembly off of drum assembly.
4. Pull spider off of drum.
5. Replace shockmounts as needed.
6. While spider is removed, inspect coupling and seal for excessive wear. Replace if needed.
7. Reinstall spider onto drum and then into the frame
8. Install motor, align with coupler and secure with mounting screw and lock washer. Use a medium strength thread locker. Make sure motor mount surface bottoms out in frame.
9. Connect hoses.

## Replacing Input Seal

Refer to Main Assembly, page 14.

1. Remove drum assembly from frame and spider from drum (See "replacing shockmounts" steps 1-4)
2. Using a seal puller, remove seal. Note it is not necessary to remove gear coupler (#15)
3. Inspect the sealing surface on the shaft for wear or damage.
4. If the shaft has any sign of wear or damage, remove the gear coupler (#15) and use the sleeve included with seal. (Follow instructions included with seal kit). If the shaft is in good condition install only the seal. Use a seal protector when installing the seal.

## Removing Drive Coupler

Refer to Main Assembly, page 14.

1. Remove hydraulic lines from motor.
2. Remove hydraulic motor (# 6).
3. Remove drive coupler (# 13) gear from motor by loosening clamping screw.

4. To remove coupler gear (# 15) from exciter shaft will require 07353 clutch removal tool. Turn coupler gear clockwise (left hand threads) to remove.

## Installing Drive Coupler

Refer to Main Assembly, page 14.

1. Install new coupler gear (# 15) into shaft. Make sure coupler bottoms out. Use high strength threadlocker.
2. Slide new coupler gear on to motor splines and tighten clamping screw. Use a medium strength thread locker on the screw.
3. Install motor (# 6), align with coupler and secure with mounting screw (# 23) and lock washer (# 24). Use a medium strength thread locker. Make sure motor mount surface bottoms out in frame.
4. Connect hoses.

## Removing Exciter Bearings and Shaft.

**Whenever a complete disassembly is done all bearings, gaskets, O-rings and seals should be replaced.**

Refer to Drum Assembly, page 12.

1. Drain exciter oil (Refer to Changing Exciter Oil, page 5.)
2. Remove drum assembly from frame and spider from drum (Refer to Replacing Shockmounts, page 7. Steps 1-4).
3. Remove input seal (# 10) from housing (# 14) using a seal puller.
4. Remove snap ring (# 9) from exciter shaft through seal bore.
5. Remove six bolts (# 19), securing housing (#14), to the drum.
6. Remove two push off bolts (# 19)
7. Thread two 3/8-16x1 1/2 bolts into these push off holes evenly and push cover (# 14) off of drum. (If bolts are not threaded in evenly the cover will bind) Remove cover.
8. Slide exciter shaft (#13) out of drum.
9. Repeat steps 5-7 to remove cover (# 5) from the other side.
10. Remove breather cover (# 11) by removing four screws (# 17).
11. Remove bearings (# 8) from covers (# 5 & 14). (Bearings must be replaced if removed from covers)

## Installing Exciter Bearings and Shaft.

Refer to Drum Assembly, page 12.

1. Install new bearings (# 8) into housings (# 5 & 14). Use oil on the OD of the bearing and press on the outer race of the bearing. Failure to do so will result in damage to the bearings.
2. Install new O-rings (# 7) onto housing (# 5 & 14), lightly grease O-ring and housing surface which slides into the drum.
3. Install exciter shaft (# 13) into drum. Leave seal side of exciter assembly stick out of the drum about 12".
4. Take the seal side housing assembly (# 14), lightly oil the exciter shaft bearing journal and apply Loctite 515 gasket eliminator, or equivalent, to mating flange. Slide housing assembly onto shaft and install snap ring (# 9) through seal bore onto shaft. Do not install seal at this time.
5. Slide exciter shaft and housing assembly into drum. Use care to press housing in evenly. Secure with six bolts (# 19). Use medium strength thread locker. Install two bolts (# 18) in the push out holes to protect the threads.
6. To aid in assembly, insert a piece of 3/4" round stock in the vent end of the exciter shaft. Take vent side housing assembly (# 5), apply a light coat of oil to the exciter shaft bearing journal, and Loctite 515 gasket eliminator, or equivalent, to the mating flange. Slide housing assembly over the 3/4" round stock, exciter shaft, and onto drum assembly. Have someone lift up the exciter shaft while aligning the housing assembly with mounting holes in the drum and slide the assembly on evenly.
7. Install the six bolts (# 19) use medium strength thread locker. Install two bolts (# 18) in the push out holes to protect threads. Make sure exciter assembly rotates freely.
8. Remove 3/4" round stock and install vent cover (# 11). Make sure felt filter (# 1), retainer (# 2) and spiral pin (# 15) are in place.
9. Press seal into housing (# 14) using care to keep seal square with bore.
10. Fill exciter housing with exciter oil. Refer to Changing Exciter Oil, page 5. or proper procedure and amount.
11. Install drive gear coupler (# 16, page 14) if removed.
12. Install spiders and frame.

**Parts Replacement Cycles and Tolerances**

<b>Bearings</b>	Replace anytime a bearing is rough, binding, discolored or removed from housing or shaft.
<b>Hardware</b>	Replace any worn or damaged hardware as needed. Replacement hardware should be grade 5 and zinc plated unless otherwise specified.
<b>Safety Decals</b>	Replace if they become damaged or illegible.
<b>Seals &amp; Gaskets</b>	Replace if a leak is detected and at every overhaul or tear down.

**This page intentionally left blank.**

# REPLACEMENT PARTS

---

The warranty is stated in this book on page 18. Failure to return the Warranty Registration Card renders the warranty null and void.

MBW has established a network of reputable distributors/dealers with trained mechanics and full facilities for maintenance and rebuilding, and to carry an adequate parts stock in all areas of the country. Their sales engineers are available for professional consultation. If you cannot locate an MBW distributor in your area, contact MBW or one of our Sales Branches listed below.

When ordering replacement parts, be sure to have the following information available:

- Model and Serial Number of machine when ordering MBW parts
- Model and Serial Number of engine when ordering engine parts
- Part Number, Description, and Quantity
- Company Name, Address, Zip Code, and Purchase Order Number
- Preferred method of shipping

**REMEMBER - You own the best! If repairs are needed, use only MBW parts purchased from authorized MBW distributors.**

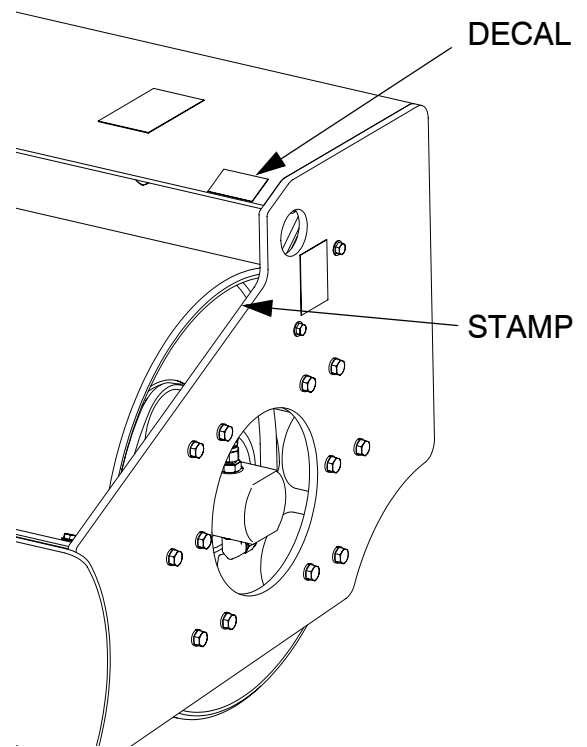

The unit's serial number can be found in the following locations:

- The model and serial number are on the top front of the roller frame
- The serial number is also stamped on the frame side

**Write Model Number here**

**Write Serial Number here**

---

## Contact Information

### **MBW, Inc.**

250 Hartford Rd • PO Box 440  
Slinger, WI 53086-0440  
Phone: (262) 644-5234  
Fax: (262) 644-5169  
Email: [mbw@mbw.com](mailto:mbw@mbw.com)  
Website: [www.mbw.com](http://www.mbw.com)

### **MBW (UK) Ltd.**

Units 2 & 3 Cochrane Street  
Bolton BL3 6BN, England  
Phone: 01204 387784  
Fax: 01204 387797

### **MBW France S.A.R.L**

Z.A. d'Outreville  
11 rue Jean Baptiste Néron,  
60540 BORNEL  
France  
Phone: +33 (0) 3 44 07 15 96  
Fax: +33 (0) 3 44 07 41 28

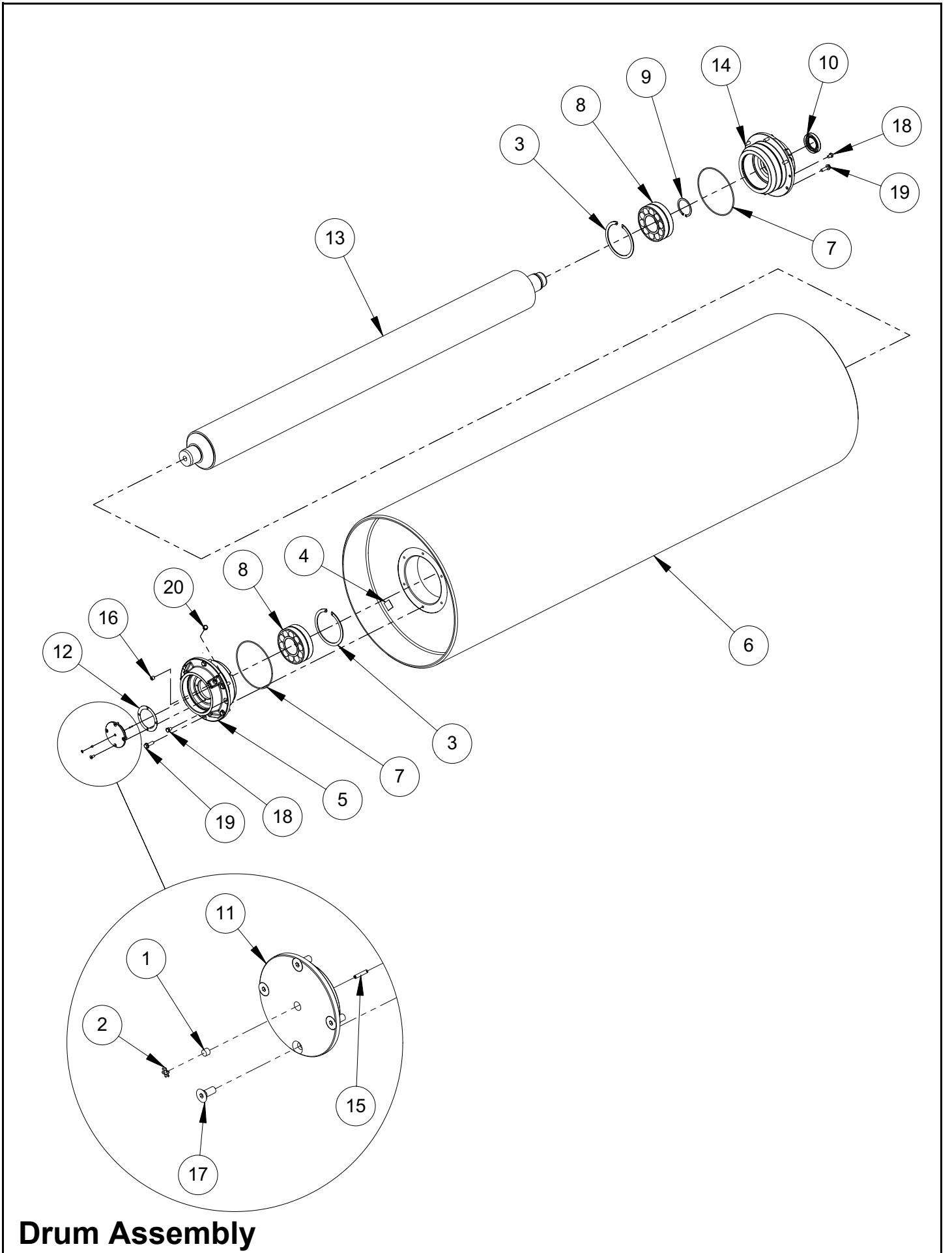

**Drum Assembly**

ITEM	PART NO.	DESCRIPTION	ATP73	ATS73	ATP84	ATS84
1.	01072	FILTER, FELT	1	1	1	1
2.	01191	RETAINING RING, INTERNAL, STAR	1	1	1	1
3.	07011	RETAINING RING, INTERNAL	2	2	2	2
4.	08188	DECAL, EXCITER OIL	2	2	2	2
5.	17807	COVER, EXCITER, BREATHER SIDE	1	1	1	1
6.	17911	DRUM, ATP73 (PADDED)	1	0	0	0
	17811	DRUM, ATS73 (SMOOTH)	0	1	0	0
	17913	DRUM, ATP84 (PADDED)	0	0	1	0
	17813	DRUM, ATS84 (SMOOTH)	0	0	0	1
7.	17844	O-RING, 7.234 ID X 0.139 DIA	2	2	2	2
8.	17845	BEARING, SPHERICAL ROLLER	2	2	2	2
9.	17846	RETAINING RING, EXTERNAL	1	1	1	1
10.	18111	KIT, SEAL, AT73-84	1	1	1	1
11.	17853	COVER, BREATHER	1	1	1	1
12.	17854	GASKET, COVER	1	1	1	1
13.	17858	SHAFT, AT73	1	1	0	0
	17859	SHAFT, AT84	0	0	1	1
14.	17938	COVER, EXCITER, SEAL SIDE	1	1	1	1
15.	F0205SP	PIN, SPIROL 1/8" X 5/8"	1	1	1	1
16.	F0418SPP	SOCKET PIPE PLUG, 1/4"-18	2	2	2	2
17.	F042005FSS	FLAT HEAD SOCKET SCREW, 1/4"-20 X 5/8"	4	4	4	4
18.	F061604HCS	HEX HEAD CAP SCREW, 3/8"-16 X 1/2"	4	4	4	4
19.	F061610FWS	FLANGE HEAD CAP SCREW, 3/8"-16 X 1-1/4"	12	12	12	12
20.	F0618SHPP	SQUARE HEAD PIPE PLUG, 3/8"-18	1	1	1	1



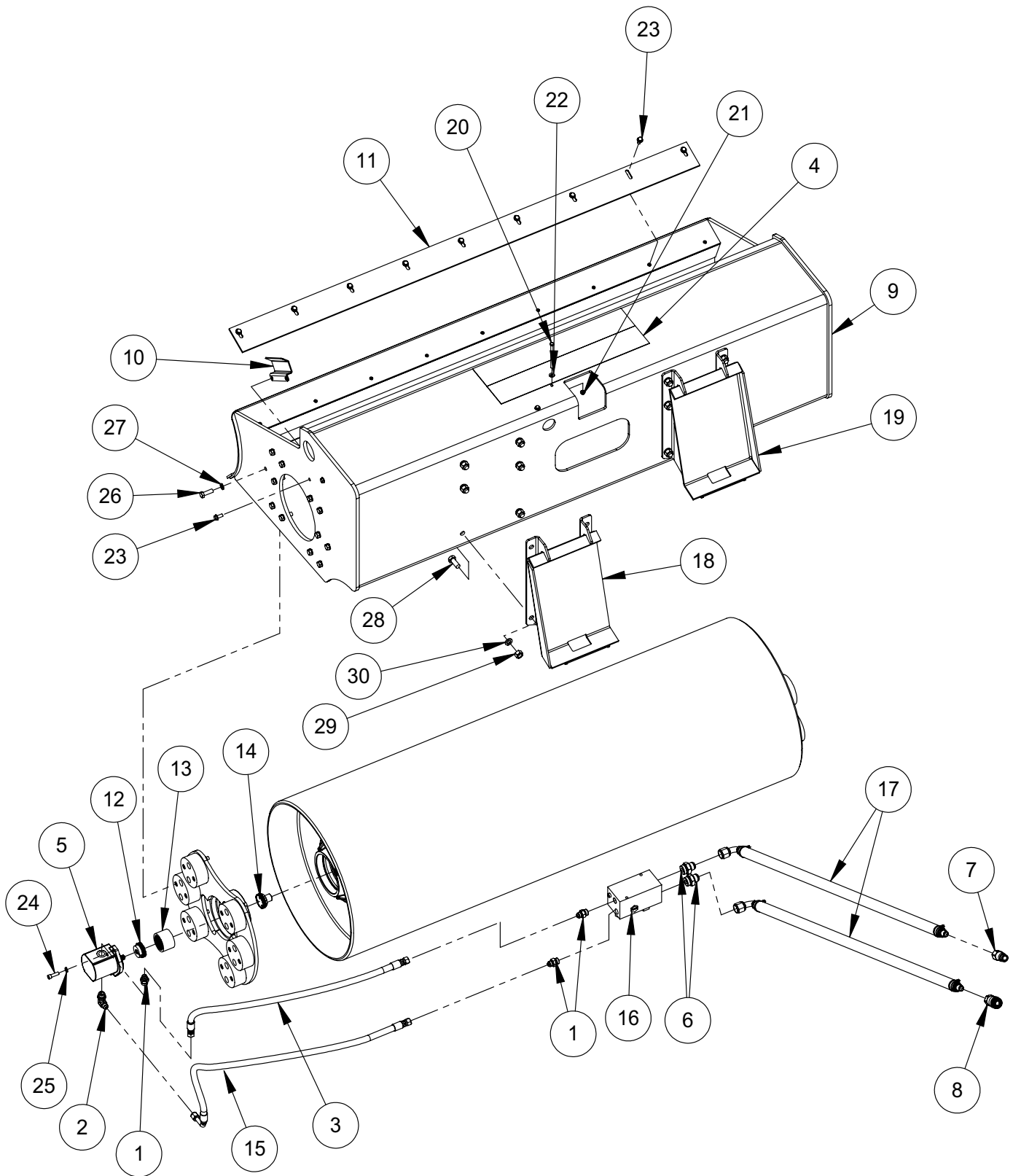

# Main Assembly

ITEM	PART NO.	DESCRIPTION	ATP73	ATS73	ATP84	ATS84
1.	08213	FITTING, STRAIGHT	3	3	3	3
2.	08730	FITTING, ELBOW	1	1	1	1
3.	13166	HOSE, HYDRAULIC 1/2" X 47.00"	1	1	0	0
	17980	HOSE, HYDRAULIC 1/2" X 55.00"	0	0	1	1
4.	13984	SHEET, SAFETY WALK 24"	2	2	2	2
5.	14267	MOTOR, HYDRAULIC	1	1	1	1
6.	14747	FITTING, STRAIGHT	2	2	2	2
7.	17842	FLAT FACE COUPLING, MALE 1/2"	1	1	1	1
8.	17843	FLAT FACE COUPLING, FEMALE 1/2"	1	1	1	1
9.	17850	FRAME, AT73	1	1	0	0
	17851	FRAME, AT84	0	0	1	1
10.	17856	GAURD, HOSE	1	1	1	1
11.	17924	SCRAPER BAR ATP73 (PADDED)	1	0	0	0
	17894	SCRAPER BAR ATS73 (SMOOTH)	0	1	0	0
	17925	SCRAPER BAR ATP84 (PADDED)	0	0	1	0
	17895	SCRAPER BAR ATS84 (SMOOTH)	0	0	0	1
12.	17975	COUPLER, GEAR, 9T SPLINE	1	1	1	1
13.	17976	SLEEVE, COUPLER, GEAR	1	1	1	1
14.	17977	COUPLER, GEAR, 1"-12 THREAD	1	1	1	1
15.	17981	HOSE, HYDRAULIC 1/2" X 53.5"	1	1	0	0
	17979	HOSE, HYDRAULIC 1/2" X 59.00"	0	0	1	1
16.	18107	VALVE COMBINATION (.203 ORIFICE)	1	1	1	1
17.	18127	HOSE, HYDRAULIC 3/4" X 64.00"	2	2	2	2
18.	18656	BRACKET, LEFT	1	1	1	1
19.	18657	BRACKET, RIGHT	1	1	1	1
20.	F051836HCS	HEX HEAD CAP SCREW, 5/16"-18 X 4-1/2"	2	2	2	2
21.	F0518FN	NUT, FLANGE 5/16"-18	2	2	2	2
22.	F05SW	WASHER, 5/16" X 3/4" X 15GA	2	2	2	2
23.	F061607FWS	FLANGE HEAD CAP SCREW, 3/8"-16 X 7/8"	11	11	11	11
24.	F061610SCS	SOCKET HEAD CAP SCREW, 3/8"-16 X 1-1/4"	2	2	2	2
25.	F06LW	LOCKWASHER, 3/8"	2	2	2	2
26.	F081312HCS	HEX HEAD CAP SCREW, 1/2"-13 X 1-1/2"	24	24	24	24
27.	F08LW	LOCKWASHER, 1/2"	24	24	24	24
28.	F101112HCS	HEX HEAD CAP SCREW, 5/8"-11 X 1-1/2"	8	8	8	8
29.	F1011HN	NUT, HEX 5/8"-11	8	8	8	8
30.	F10LW	LOCKWASHER, 5/8"	8	8	8	8
	17994	<u>NOT SHOWN</u> SEAL KIT FOR 14267 HYDRAULIC MOTOR	1	1	1	1

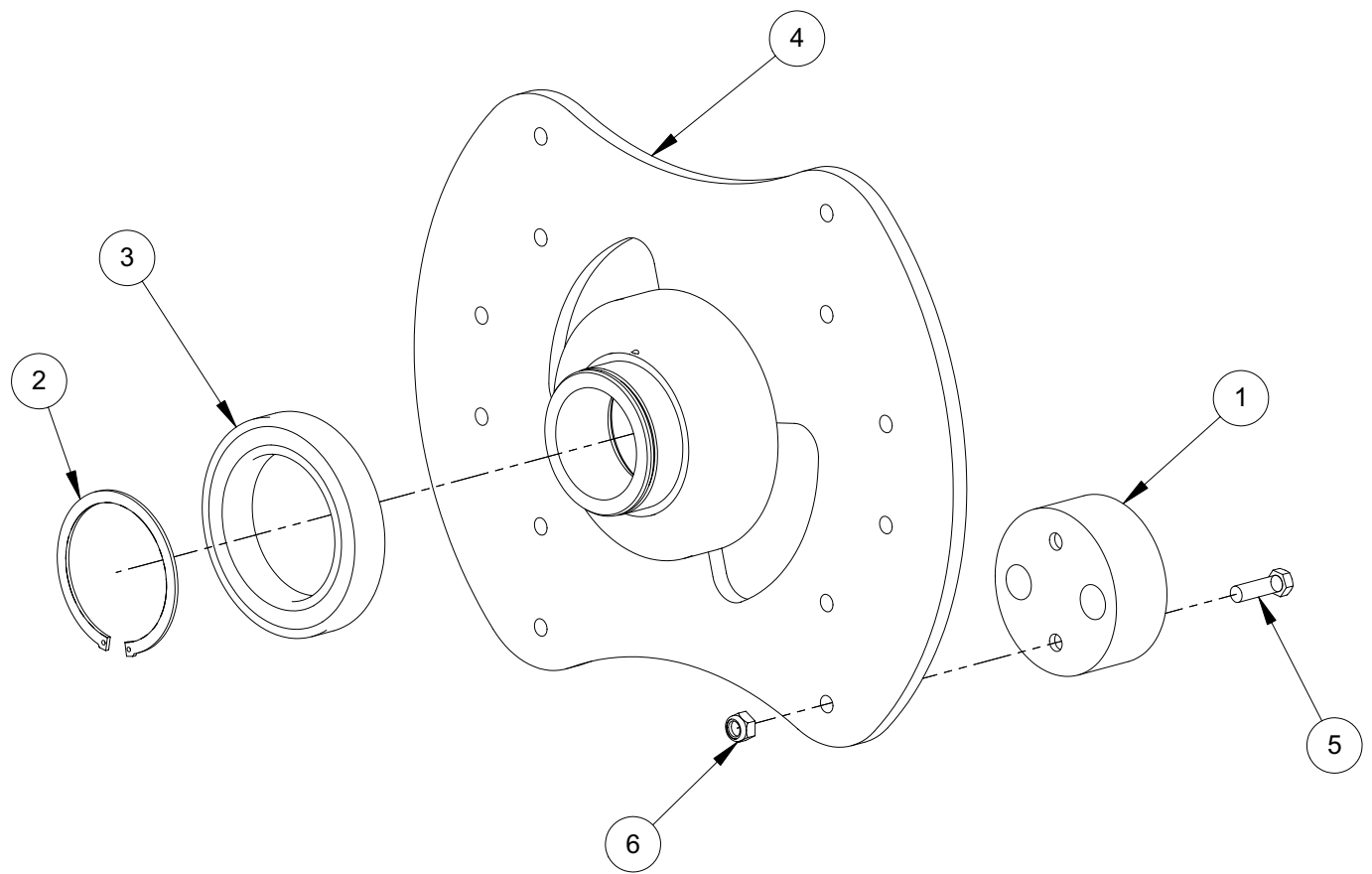

# Spider Assembly



# WARRANTY

**WHAT DOES THIS WARRANTY COVER?** MBW, Incorporated (MBW) warrants each New Machine against defects in material and workmanship for a period of twelve (12) months. "New Machine" means a machine shipped directly from MBW or authorized MBW dealer to the end user. This warranty commences on the first day the machine is sold, assigned to a rental fleet, or otherwise put to first use.

MBW warrants each Demonstration Machine against defects in material and workmanship for a period of six (6) months. "Demonstration Machine" means a machine used by MBW or its agents for promotional purposes. This warranty commences on the first day the machine is sold, assigned to a rental fleet, or otherwise put to first use.

This warranty covers the labor cost for replacement or repair of parts, components, or equipment on New Machines or Demonstration Machines, and MBW shall pay labor costs at MBW's prevailing rate to affect the warranted repair or replacement. MBW reserves the right to adjust labor claims on a claim-by-claim basis.

This warranty covers the shipping cost of replacement parts, components, or equipment via common ground carriers from MBW to an authorized MBW dealer. Air freight is considered only in cases where ground transportation is not practical.

**MAY THIS WARRANTY BE TRANSFERRED?** This warranty is non-transferable and only applies to the original end user of a new machine or demonstration machine.

## **WHAT DOES THIS WARRANTY NOT COVER?**

1.This warranty does not cover any Used Equipment. "Used Equipment" means any MBW machine or equipment that is not a New Machine or a Demonstration Machine. All Used Equipment is sold **AS IS/WHERE IS WITH ALL FAULTS**.

2.This warranty does not cover any New Machine, Demonstration Machine, or their equipment, parts, or components altered or modified in any way without MBW's prior written consent. This warranty does not cover the use of parts not specifically approved by MBW for use on MBW products. This warranty does not cover misuse, neglect, shipping damage, accidents, acts of God, the operation of any New Machine or Demonstration Machine in any way other than recommended by MBW in accordance with its specifications, or any other circumstances beyond MBW's control. This warranty does not cover any New Machine or Demonstration Machine repaired by anyone other than MBW factory branches or authorized MBW distributors.

3.This warranty does not cover, and MBW affirmatively disclaims, liability for any damage or injury resulting directly or indirectly from design, materials, or operation of a New Machine or Demonstration Machine or any other MBW product. MBW's liability with respect to any breach of warranty shall be limited to the provisions of this document and in no event shall exceed an amount equal to the purchase price of the New Machine or Demonstration Machine purchased from MBW.

4.This warranty does not cover engines, motors, and other assemblies or components produced by other manufacturers and used on a New Machine or Demonstration Machine, as said engines, motors, and other assemblies or components may have warranties provided by the manufacturer thereof. This warranty does not apply to consumable items, such as v-belts, filters, trowel and screed blades, seals, shock mounts, batteries, and the like, all of which are sold **AS IS/WHERE IS WITH ALL FAULTS**.

5.This warranty does not cover the cost of transportation and other expenses which may be connected with warranty service but not specifically mentioned herein.

6.This warranty does not cover any updates to any New Machine, Demonstration Machine, or any other MBW product. MBW reserves the right to improve or make product changes without incurring any obligation to update, refit, or install the same on New Machines or Demonstration Machines previously sold.

**WHAT MUST YOU DO TO OBTAIN WARRANTY COVERAGE?** Each New Machine or Demonstration Machine is accompanied by a Warranty Registration Card. You must sign, date, and return the Warranty Registration Card to the place of origin of the New Machine or Demonstration Machine, either to MBW, Inc. at P.O. Box 440, Slinger, Wisconsin 53086, MBW (UK), Ltd. at Units 2 & 3 Cochrane Street, Bolton BL3 6BN, United Kingdom or MBW FRANCE SARL at ZA D'Outreville, 5 Rue Jean Baptiste Neron, Bornel 60540 France, within ten (10) days after purchase, assignment to a rental fleet, or first use. This signed warranty card is the buyer's affirmation that he has read, understood, and accepted the warranty at the time of purchase. Failure to return the warranty card as specified herein renders the warranty null and void. In order to receive warranty coverage consideration, warranty claims must be submitted within thirty (30) days after the New Machine or Demonstration Machine fails. Warranty claims must be submitted to MBW, Inc., MBW (UK), Ltd. or MBW FRANCE SARL, and written authorization for the return of merchandise or parts under the warranty must be obtained before shipment to MBW.

**WHAT WILL MBW DO?** MBW's obligation under this warranty is limited to the replacement or repair of parts for a New Machine or Demonstration Machine at MBW factory branches or at authorized MBW distributors, and such replacement or repair is the exclusive remedy provided hereunder. Labor must be performed at an authorized MBW distributor. MBW reserves the right to inspect and render a final decision on each warranty case, and MBW's repair or replacement is solely within the discretion of MBW.

**IT IS EXPRESSLY AGREED THAT THIS SHALL BE THE SOLE AND EXCLUSIVE REMEDY UNDER THIS WARRANTY. UNDER NO CIRCUMSTANCES SHALL MBW BE LIABLE FOR ANY COSTS, LOSS, EXPENSE, DAMAGES, SPECIAL DAMAGES, INCIDENTAL DAMAGES, OR PUNITIVE DAMAGES ARISING DIRECTLY OR INDIRECTLY FROM THE USE OF THE NEW MACHINE OR DEMONSTRATION MACHINE WHETHER BASED UPON WARRANTY, CONTRACT, NEGLIGENCE, STRICT LIABILITY, OR ANY OTHER LEGAL THEORY.**

**THE FOREGOING WARRANTY IS EXPRESSLY IN LIEU OF ALL OTHER WARRANTIES, EXPRESS OR IMPLIED, INCLUDING THE WARRANTIES OF MERCHANTABILITY, FITNESS FOR USE, AND FITNESS FOR A PARTICULAR PURPOSE, AND ALL OTHER OBLIGATIONS OR LIABILITY ON MBW'S PART. MBW NEITHER ASSUMES NOR AUTHORIZES ANY OTHER PERSON TO ASSUME ON BEHALF OF MBW ANY OTHER LIABILITY OR WARRANTY IN CONNECTION WITH THE SALE OR SERVICE OF ANY NEW MACHINE, DEMONSTRATION MACHINE , OR ANY OTHER MBW PRODUCT.**

## **EXTENDED RAMMER WARRANTY - MODELS R422, R442, R482 & R483.**

This extended warranty commences on the last day of MBW's standard, one year, "limited warranty" and runs for an additional four years (48 months). This extended warranty is limited to part replacement and shipping costs of rammer **bellows and non-metallic slide bearings only**. This extended warranty does not cover labor, down time, or any other cost beyond that of component replacement and freight. This extended warranty is subject to all limitations set fourth in MBW's "limited warranty", above.